

Piedmont Community Pool Workshop Series

Piedmont Community Pool
WORKSHOP 3

The City of Piedmont
November 16, 2021

For tonight.....

Piedmont Community Pool

- *Recap: Workshop #1*
- *Recap: Workshop #2*

} **15 minutes**

- *Preferred Concept C*
- *Final Concept Design*

} **15 minutes**

- *Charrette/Critique*
- *Team Presentations*
- *Next Steps*

} **60 minutes**

2016 Master Plan



 **Counselman · Hunsaker**
AQUATICS FOR LIFE

 **HED**



Kit of Parts

Piedmont Community Pool

Site + Pools + Building = Concept

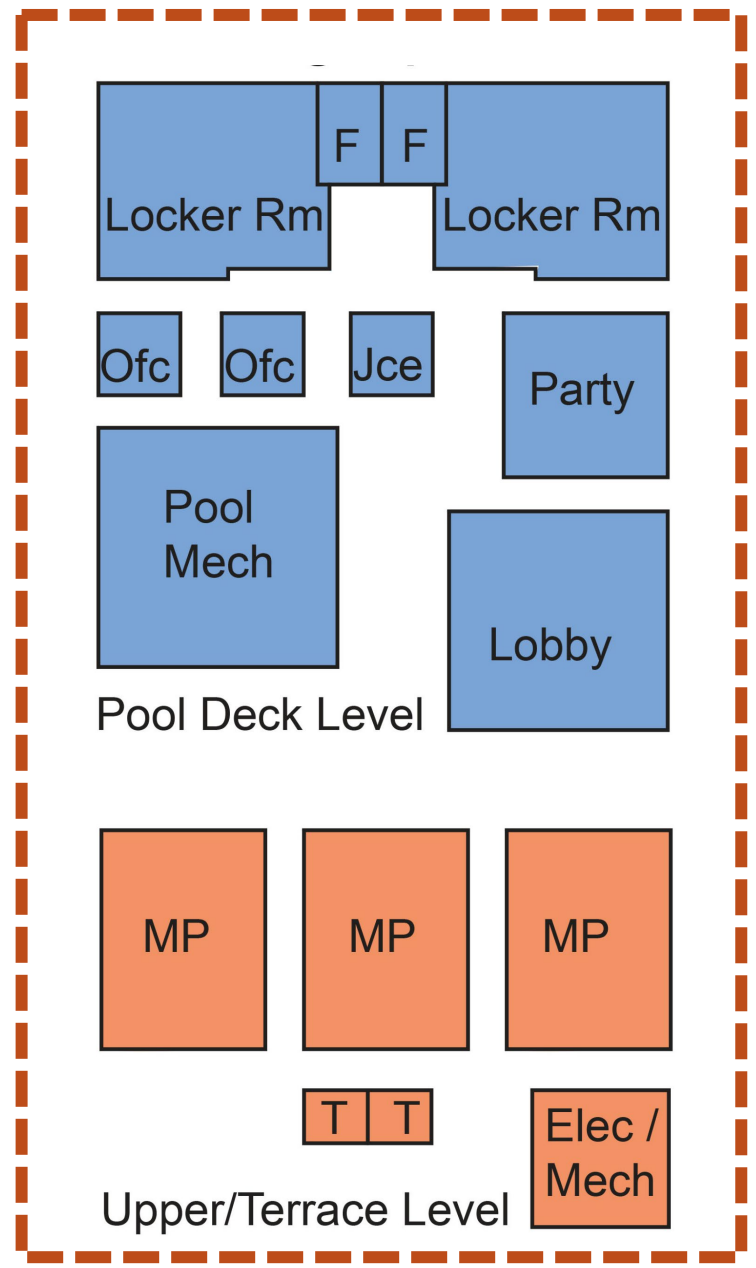
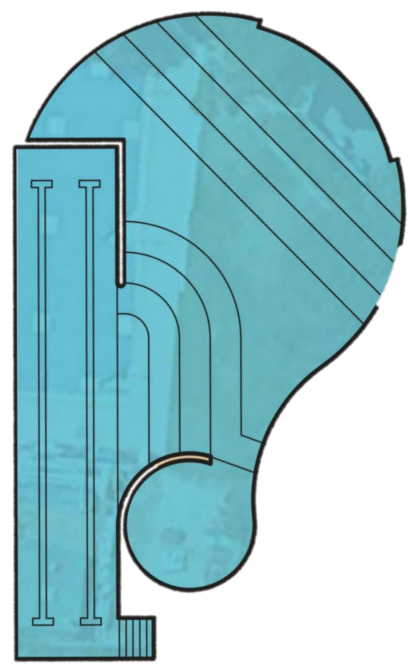
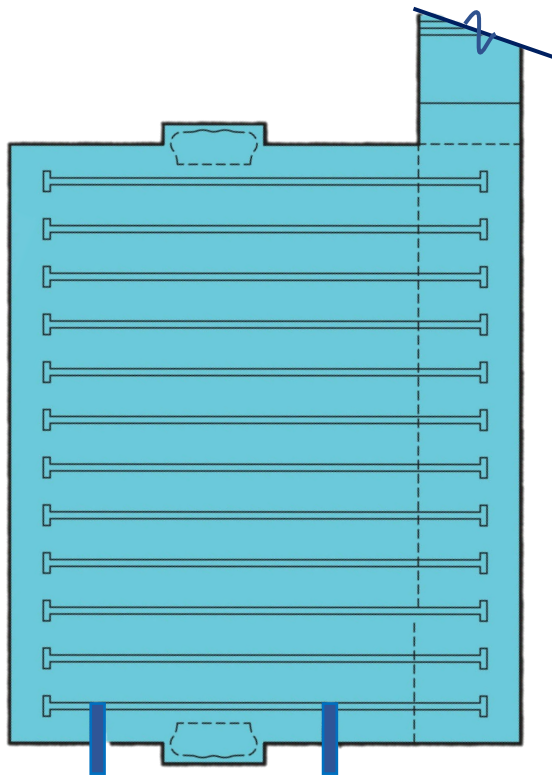

FAST WATER

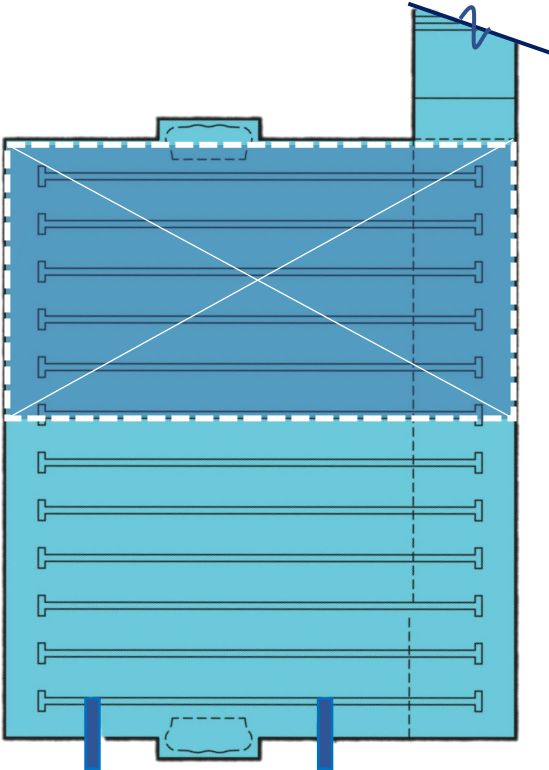

10 to 12 Lanes
27m x 25 yards

**LOWER LEVEL
(POOL DECK LEVEL)**

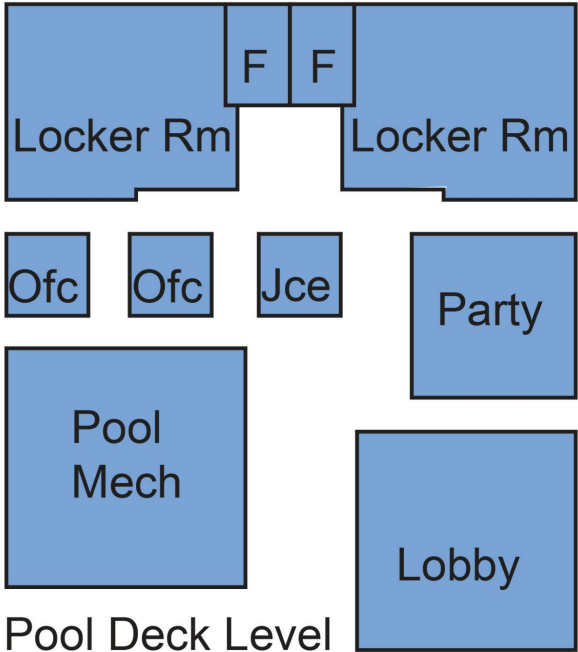

Refinement

Piedmont Community Pool

Concept A

Concept B

Concept C

Pros

- Entrance from civic center side and across from the high school - Strong civic presence
- Entrance accessibility is easy
- Pool deck seat terraces overlook Competition Pool
- Maintains picnic and play areas
- No impact to neighbor's oak tree
- Accommodates path/stair connection to tennis
- Building integrated with topography and serves as retaining wall

Cons

- Building has a strong connection to tennis
- Narrow building allows for better natural ventilation flow
- Good access to pool mechanical area
- Large roof area for PVs
- Party Room at pool deck level

- Modest deck space for seating

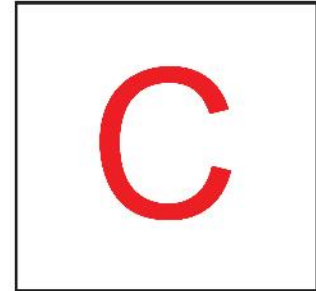
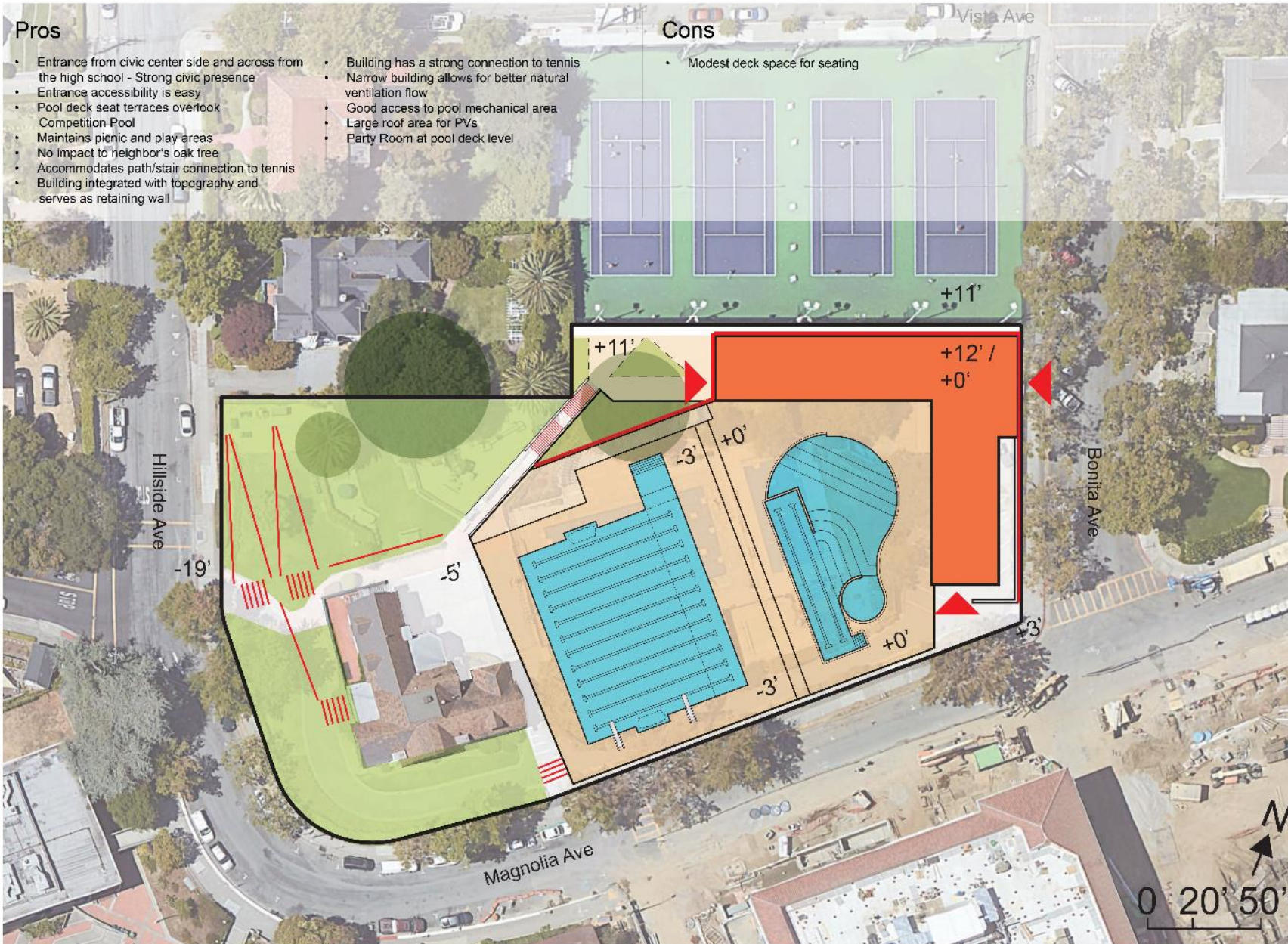

Building Spaces

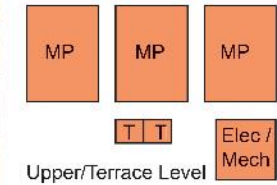
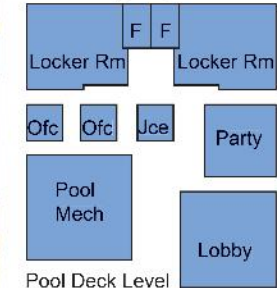

Team Number _____

Team Captain _____

Notes

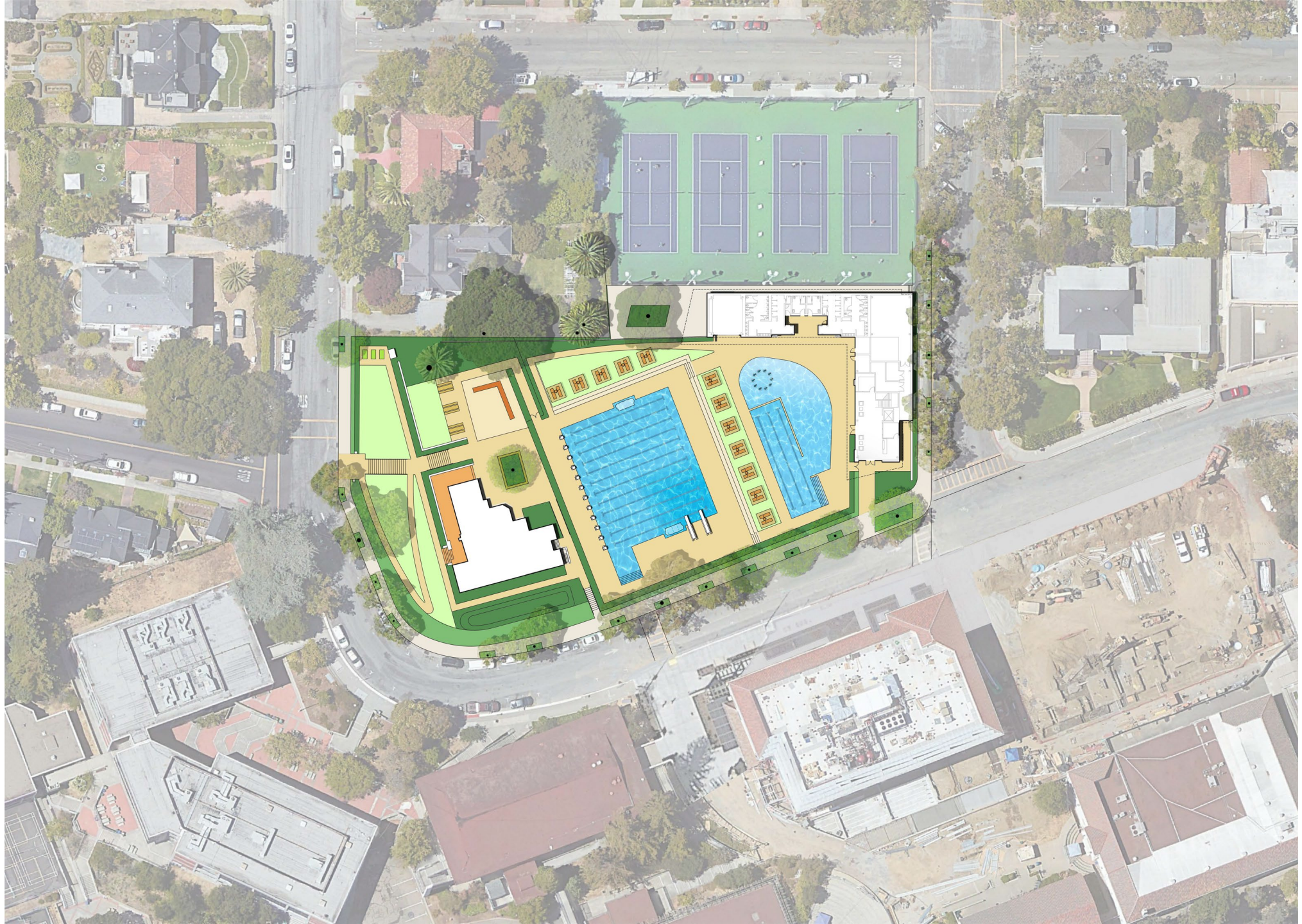

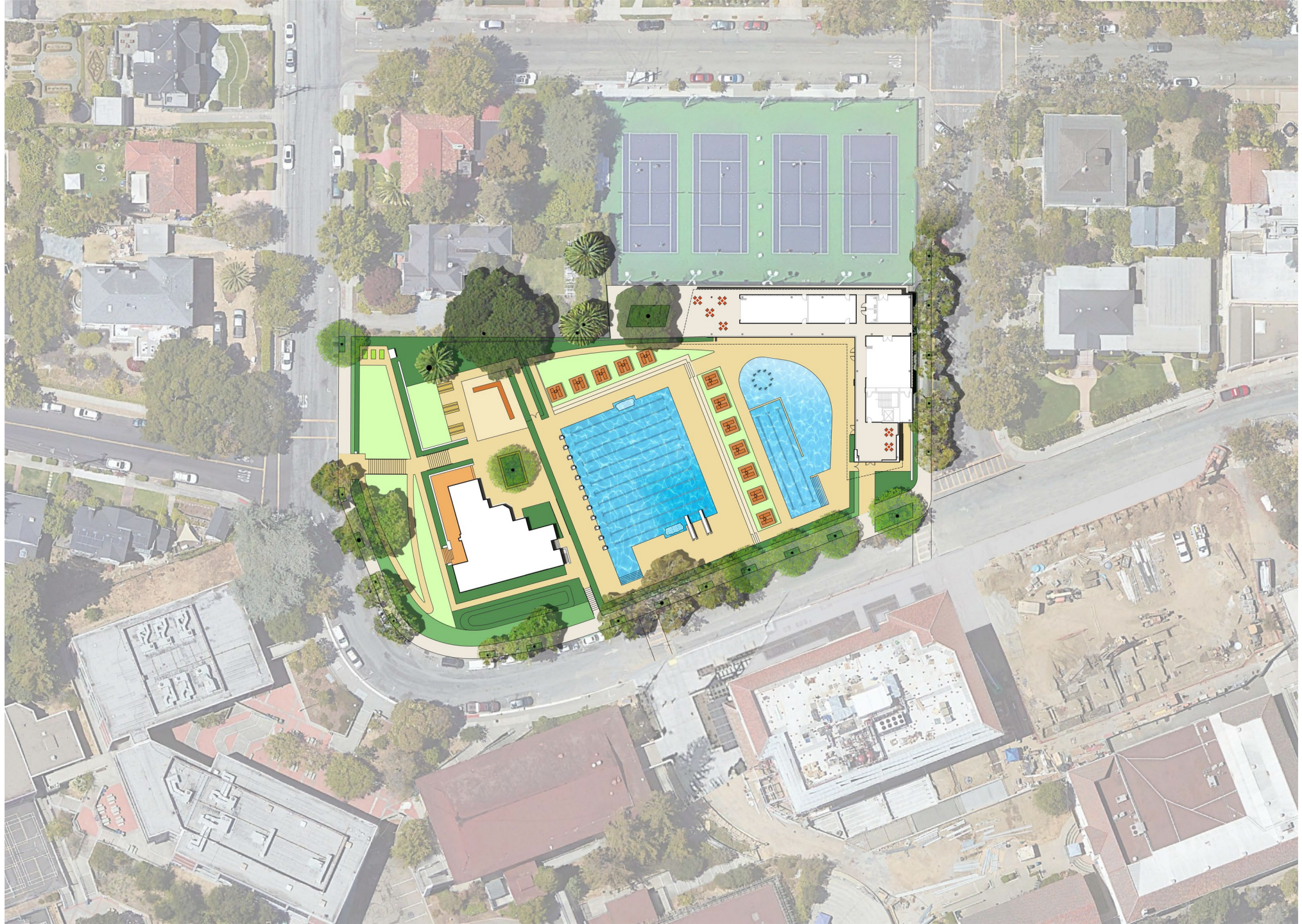

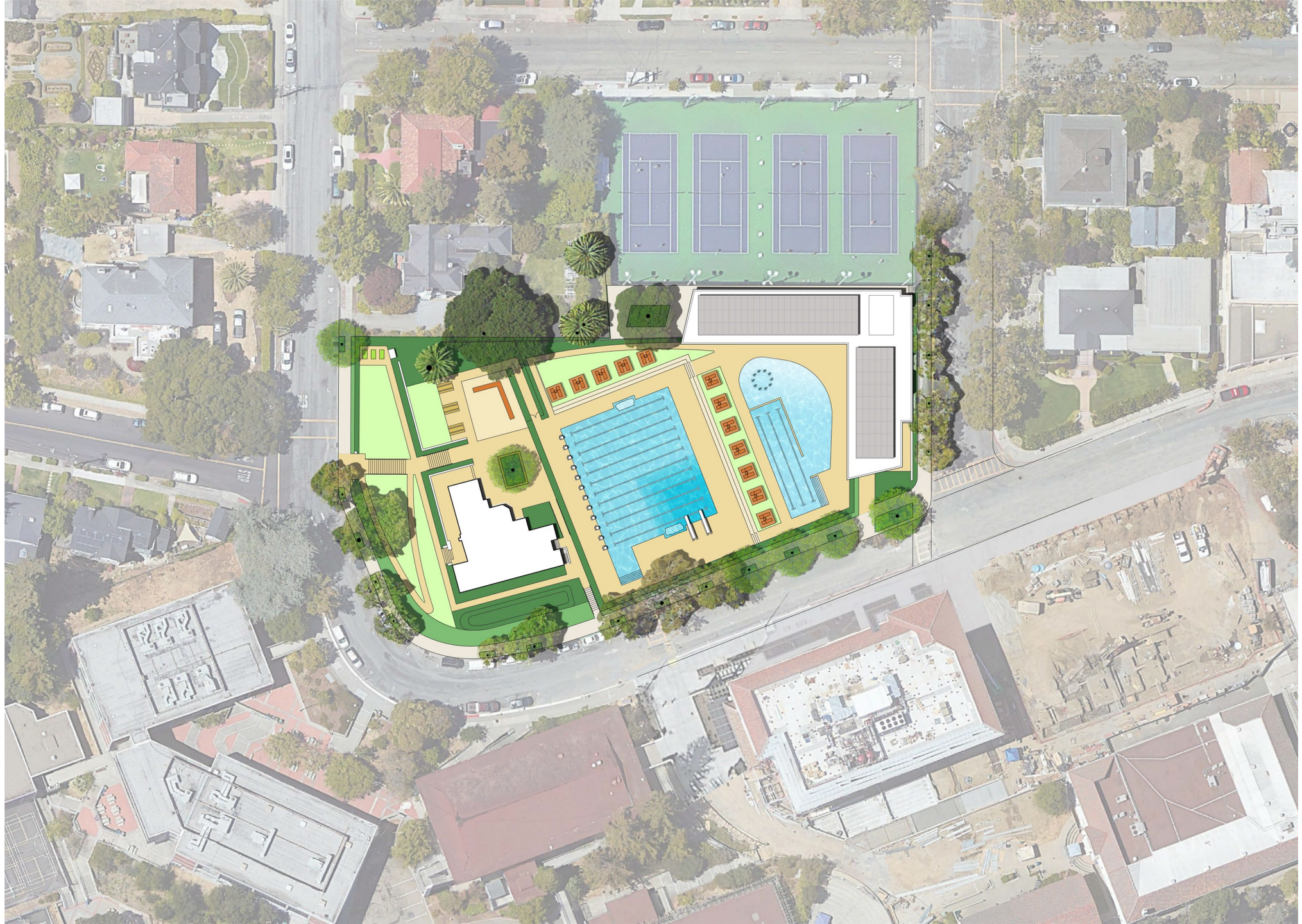

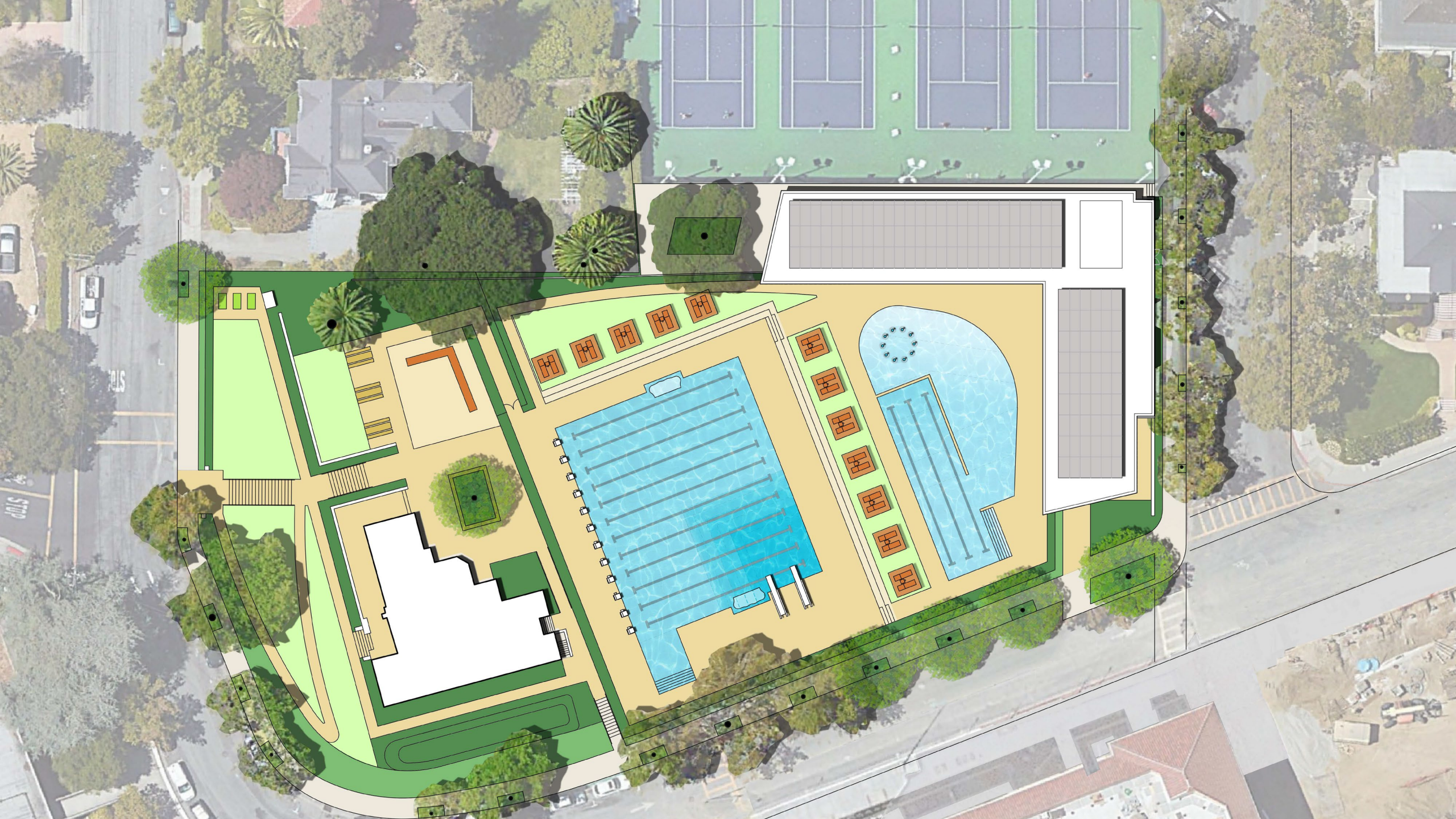

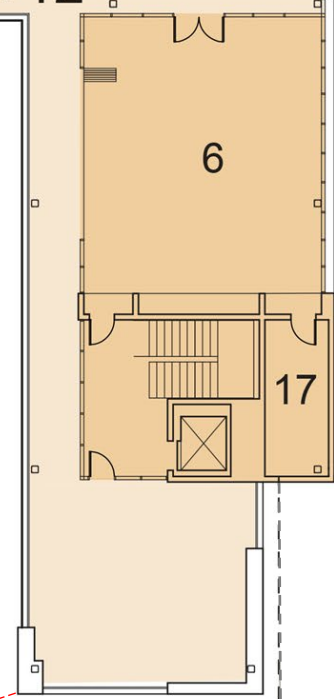
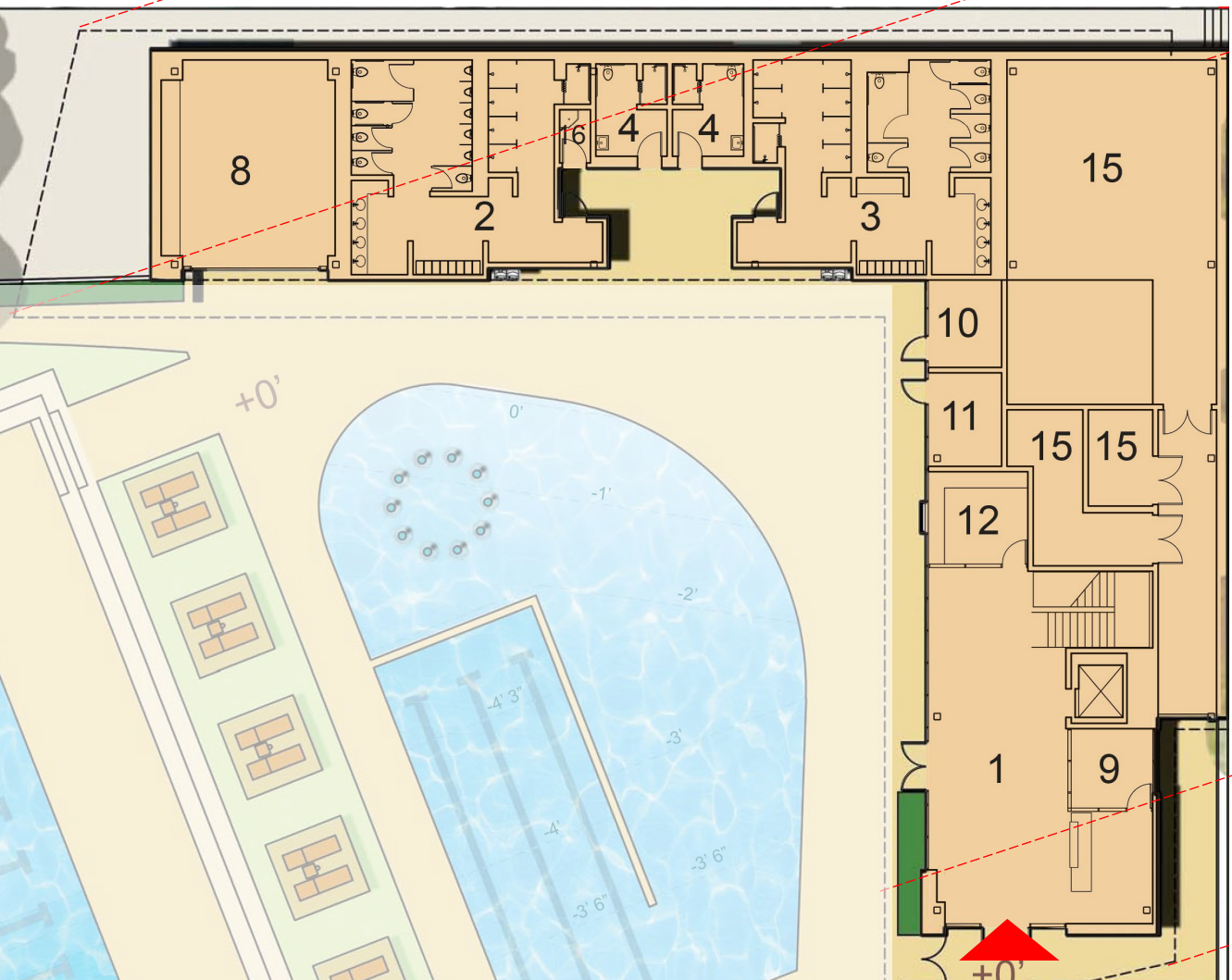
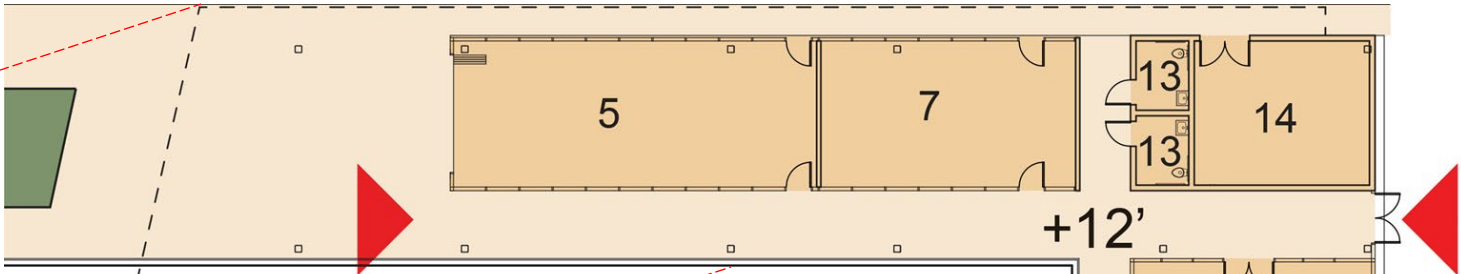
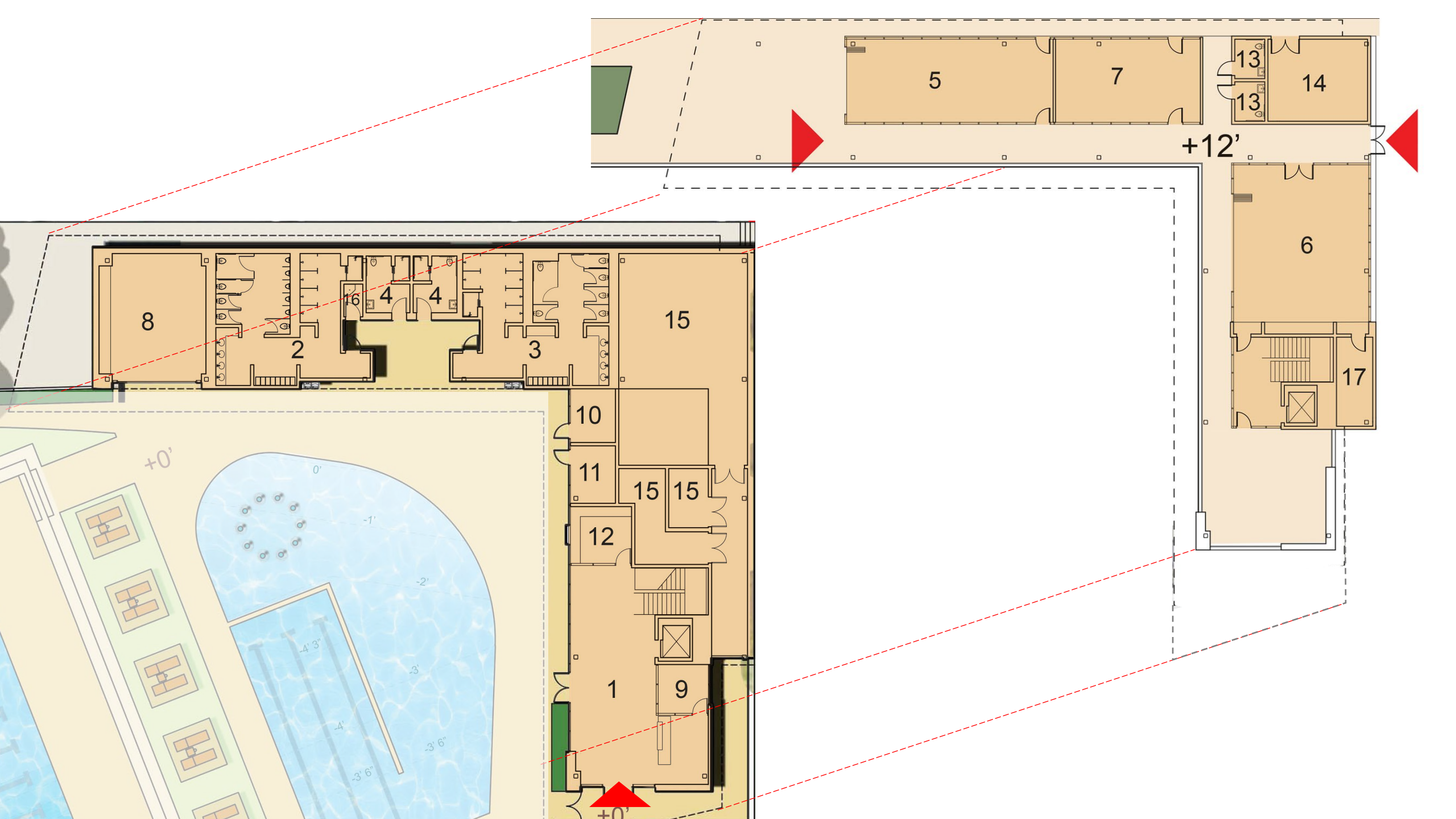



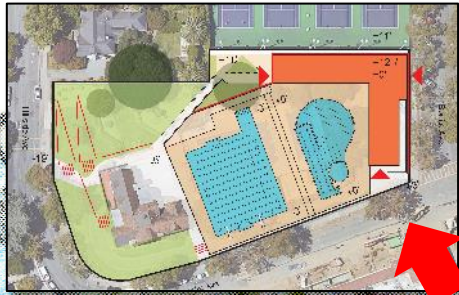



PIEDMONT
AQUATICS CENTER

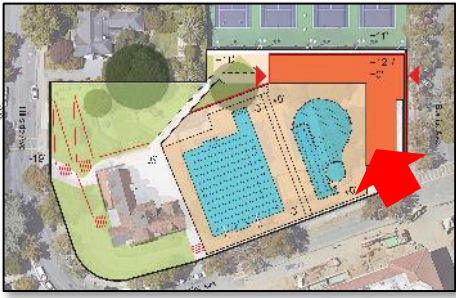





PIEDMONT
AQUATICS



Menu board with various food items and prices.

Staff members and customers at the food service counter.

Staff member at the reception desk.

Woman and young girl at the reception desk.

Man sitting on a yellow armchair, looking at his phone.

Young girl in a pink hoodie standing in the lobby.

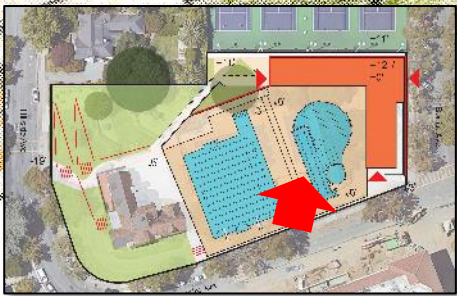
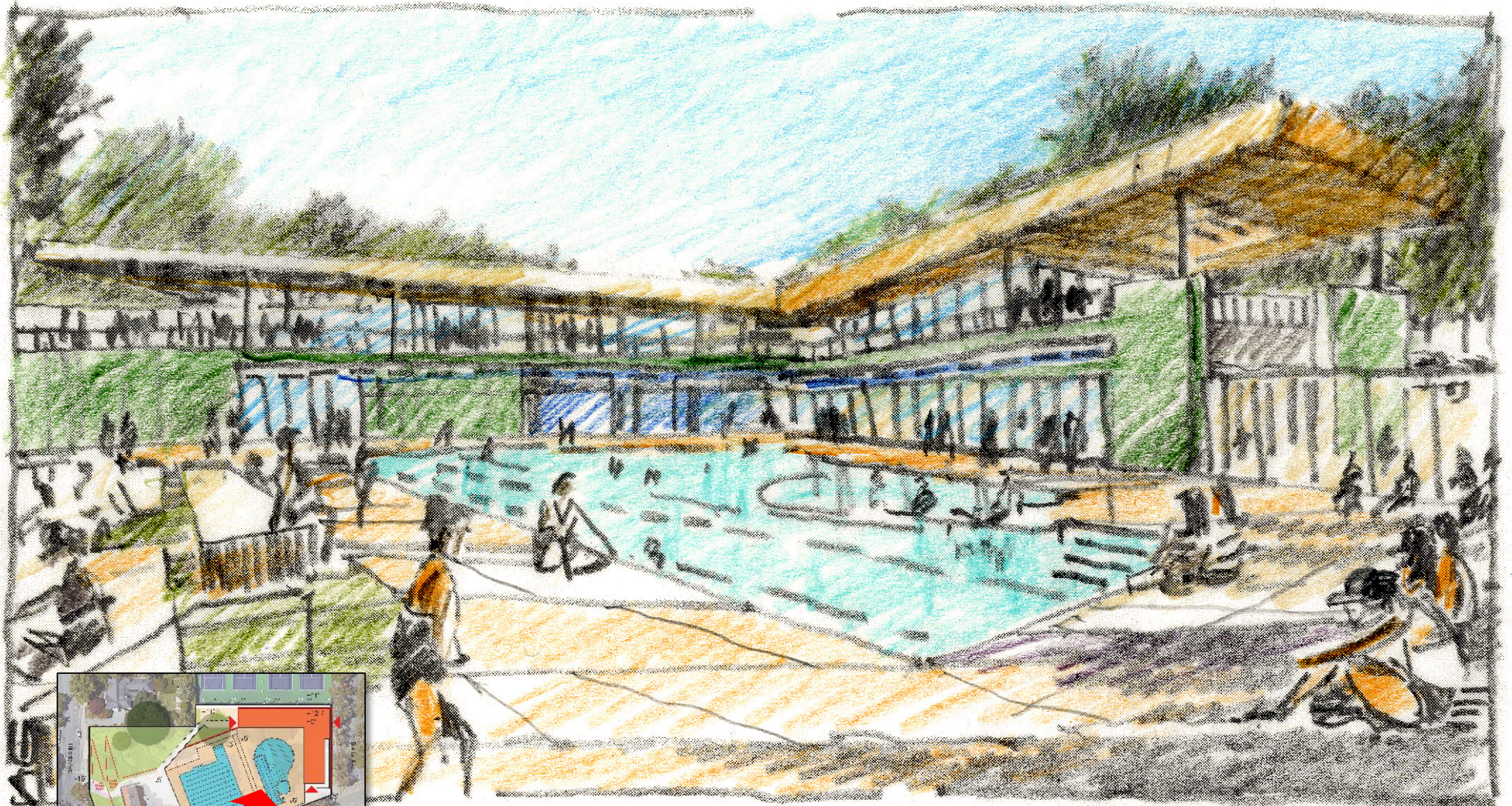













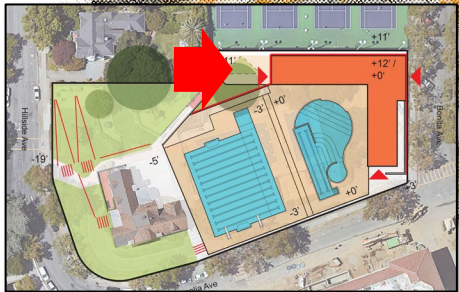
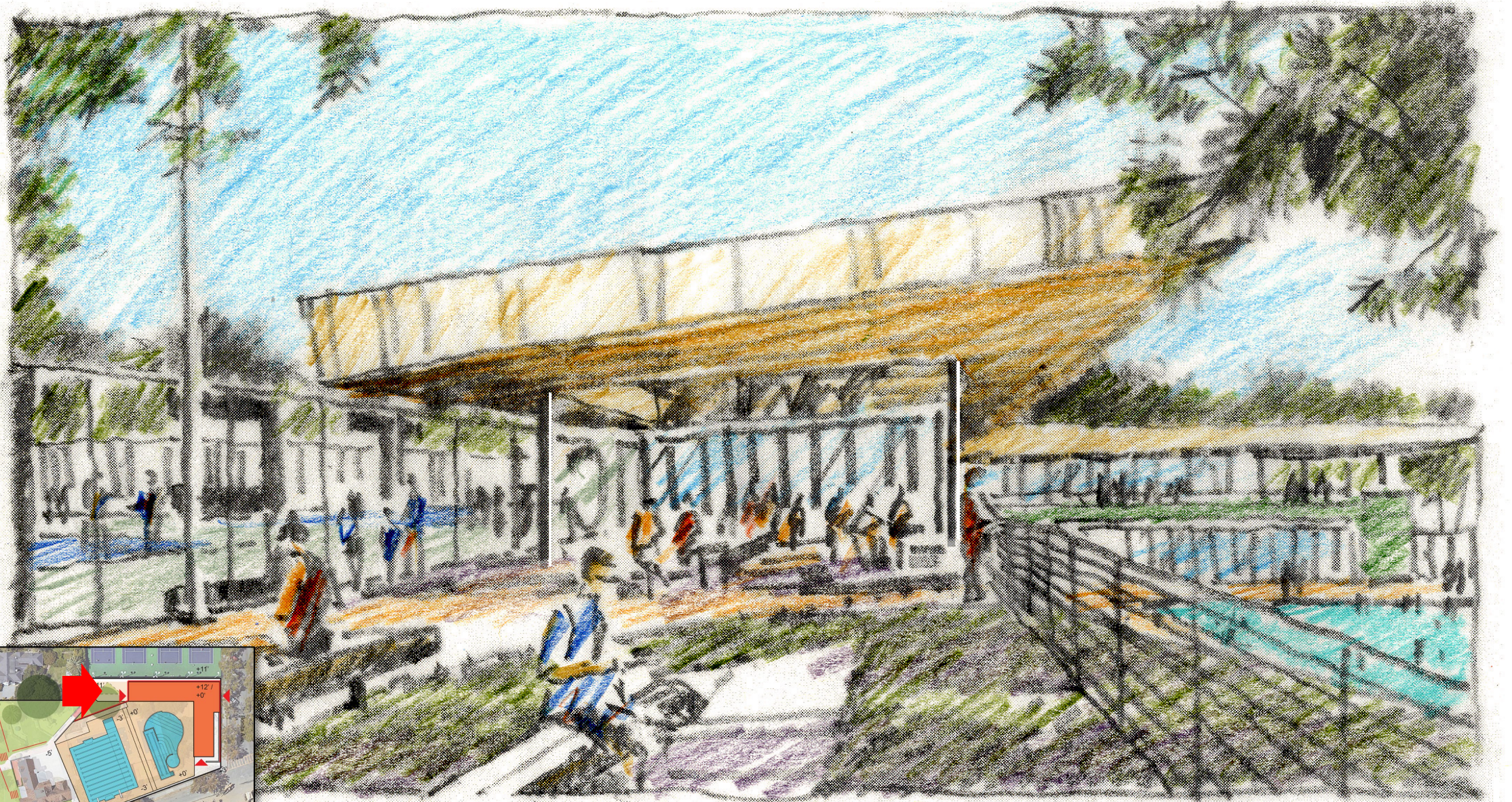





PUBLIC FORUM
REGULAR MEETING
JUNE 22, 2026



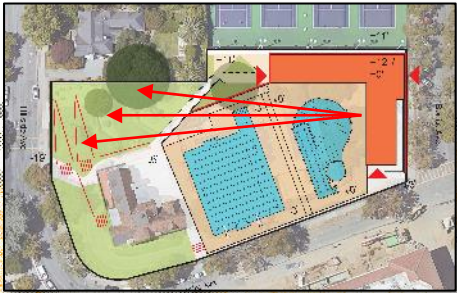
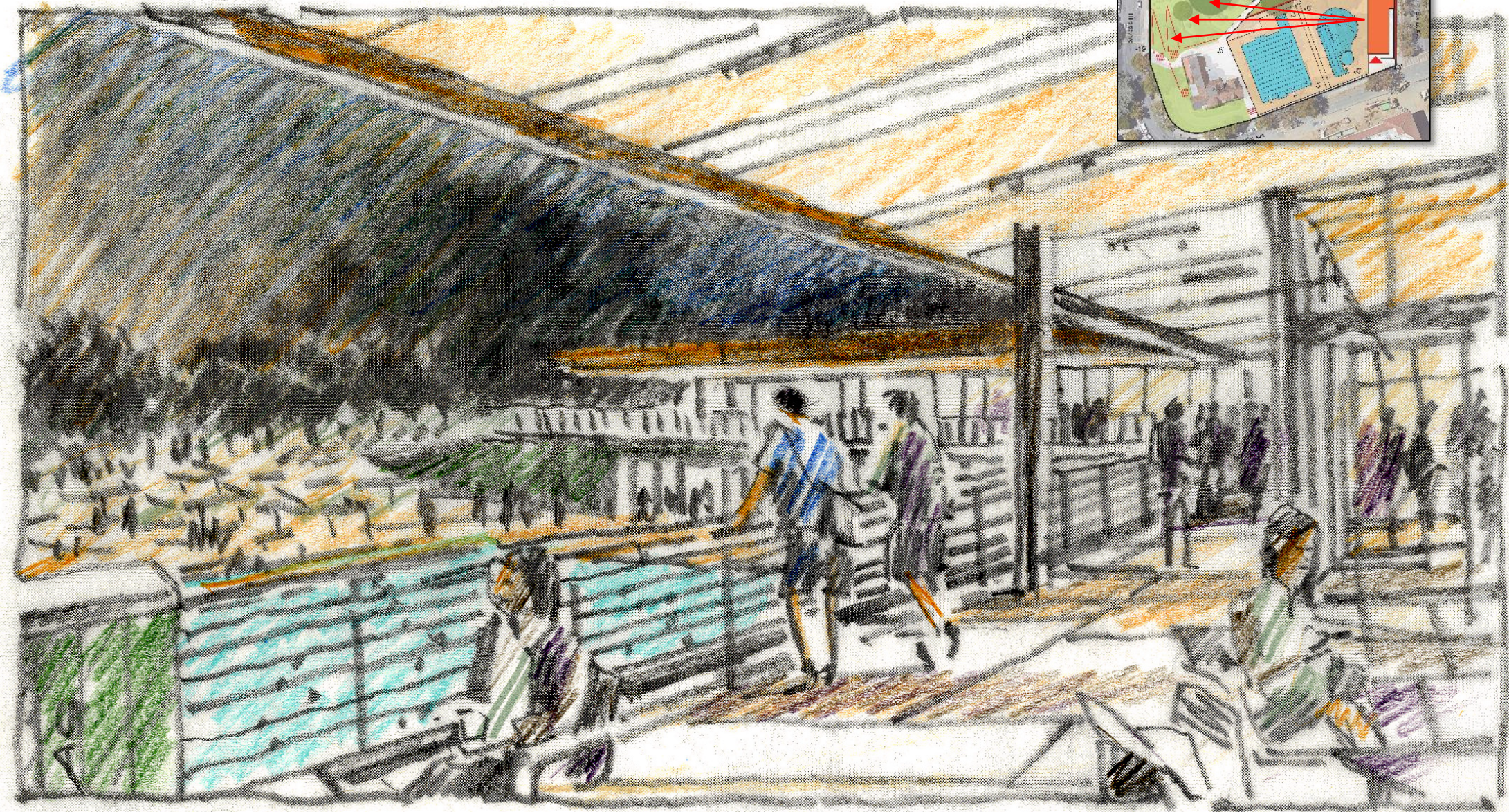





HILLSIDE PARK

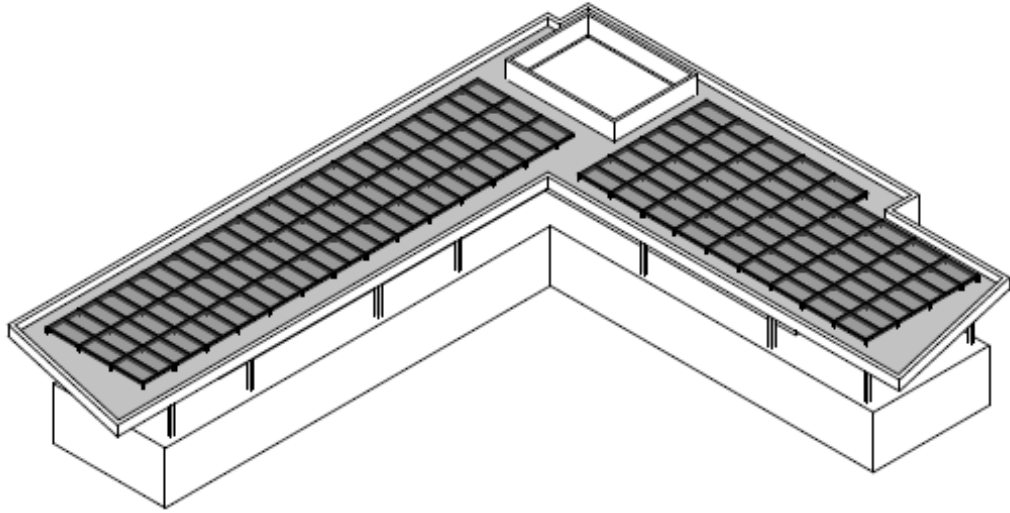

4,800 sf, PV Area

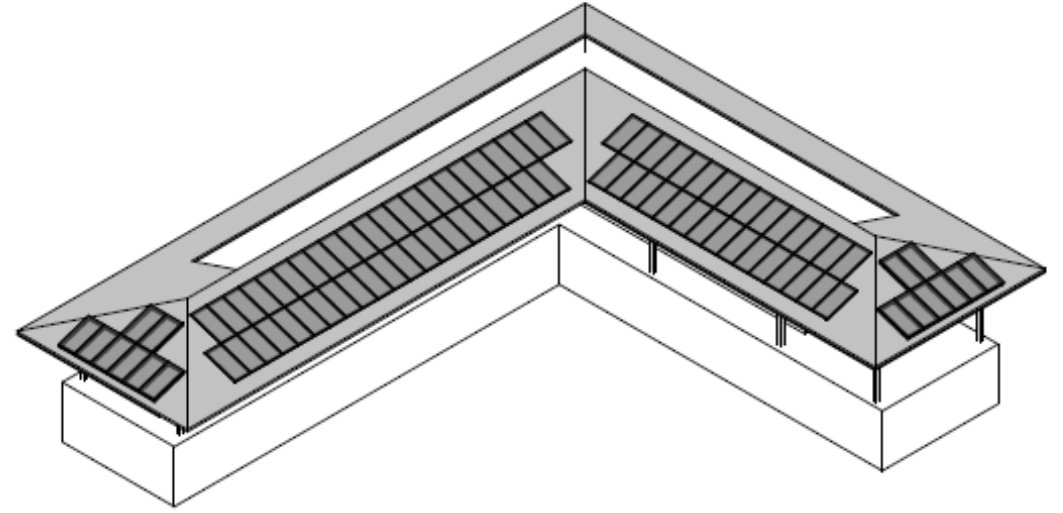

2,850 sf, PV Area

Piedmont Community Pool

Roof Form: Flat vs Hip

A RESILIENT FUTURE

- Strong seismic design under the most current codes – thus resilient to seismic activity
- Design-ready for a post-pandemic future
- Mechanical and air filtration systems to handle smoke from California Wild Fires

SOLAR ORIENTATION

Decks on southwest side of project allow for ample southern exposure on the pools



SOLAR PROTECTION

Canopies and roof overhangs protect from excess solar gain



PV/SOLAR THERMAL

hybrid panels across a flat roof maximize sources of renewable solar energy



ACTIVE AND PASSIVE VENTILATION minimize horizontal air movement and maximize vertical air movement



EFFICIENT LIGHTING STRATEGIES

including LED fixtures with automated dimming reduce energy use



INDOOR-OUTDOOR SPACES maximize access to fresh air and flexible programming



CUT AND FILL

minimize off-site hauling by repurposing the earth from the north corner retaining work to fill and level the pool decks on-site



WATER CONSERVATION OPPORTUNITIES

Drought-tolerant planting and use of pool covers contribute to overall water conservation



ALL-ELECTRIC FACILITY

PV and solar thermal strategies eliminate the need for gas, even to heat the pools



MAXIMIZE TOUCHLESS OPERATIONS

for doors, restroom fixtures, and other common use features



TRANSPARENCY AND NATURAL LIGHT

Glass and transparency provide natural light, views, and connections to nature



BIKE PARKING & IMPROVED WALKABILITY

Bike racks at entry and ease of pedestrian access encourage alternatives to motor transportation



Piedmont Community Pool

Sustainability, Resiliency and Post-Pandemic Strategies



Views



View from Hillside Ave



Site Plan / First Floor (Pool Deck Level)

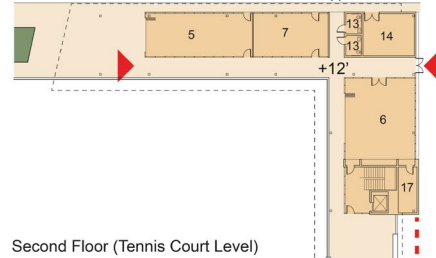

Second Floor (Tennis Court Level)



Programming Info

Plan Key

1	Lobby/Reception	845 sf
2	M Shwr/RR/Lockers	710 sf
3	W Shwr/RR/Lockers	740 sf
4	Family RR/Shwr (2 @ 100)	200 sf
5	MP Room 1	765 sf
6	MP Room 2	950 sf
7	Office/Tennis/Staff	540 sf
8	Party Room	530 sf
9	Staff Ofc (Reception)	100 sf
10	Staff Ofc (Pool)	100 sf
11	Staff Ofc (Medical/1st Aid)	100 sf
12	Juice Bar	150 sf
13	GN RR (2 @ 60)	120 sf
14	Elec/Mech	365 sf
15	Pool Mech (Pump, Filters, Acid, Chem)	1400 sf
16	Janitor	25 sf
17	Storage	145 sf
Room Area Total - Net SF		7785 sf
Building Area - Gross SF		9330 sf
2nd Floor Terraces/Walkways		2800 sf

Team Number _____

Team Captain _____

Notes



CHRISTOPHER
ELS



DANA
ELS



CLARENCE
ELS



KIM-VAN
ELS



ANTHONY
ELS



DANWEI
ELS



MARCO
SWA



ALISON
SWA



DENNIS
ADG



DAVID
ELS



WILLIAM
ELS



JOHN
ELS



SUSAN
ELS



JEFF
ELS



MARK
ELS

**Form Teams
1 – 10
Elect a Captain
Fill-in the lower right corner on each board
You have 20 Minutes**



Views

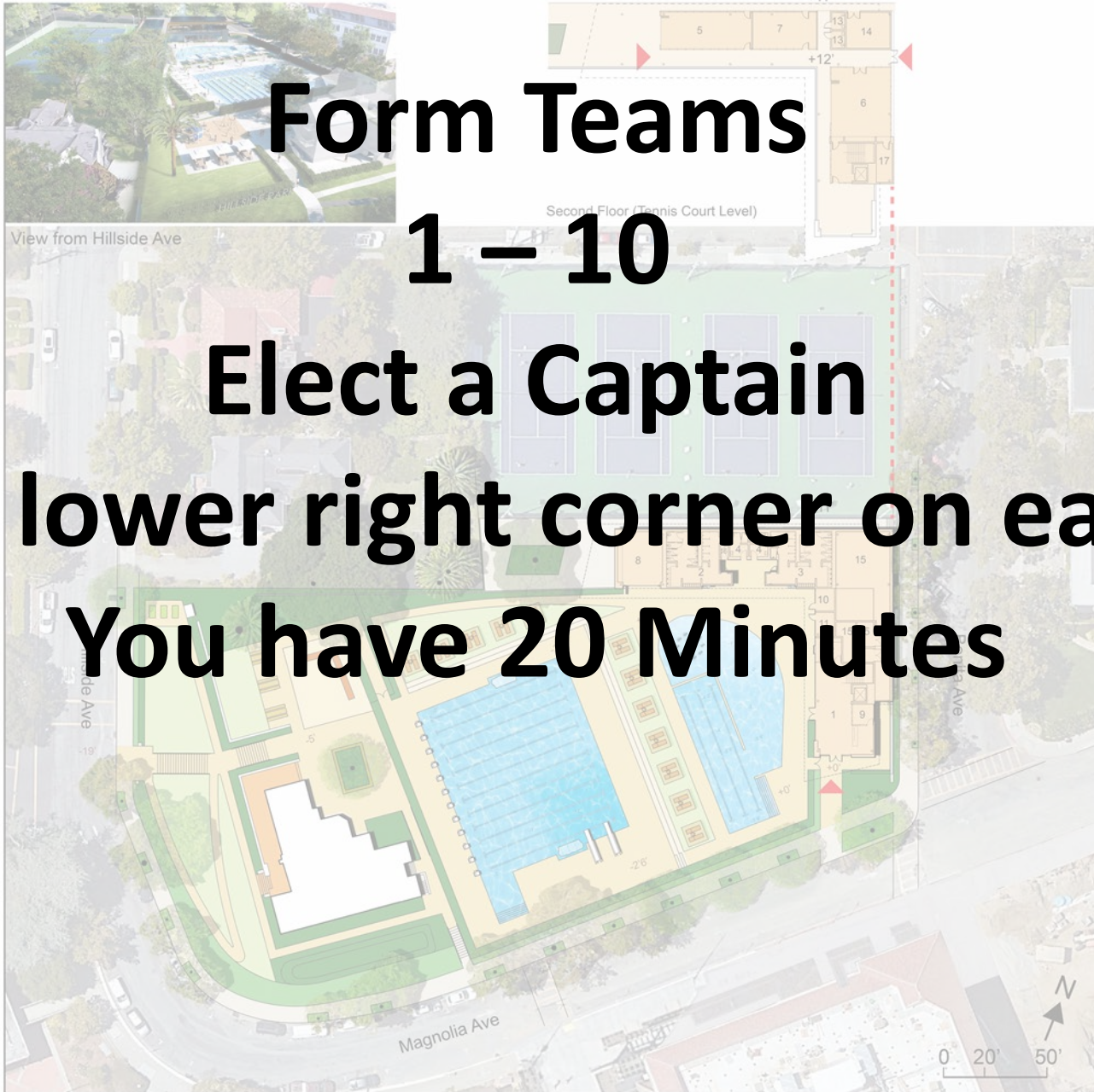

Site Plan / First Floor (Pool Deck Level)



Programming Info

Plan Key

1	Lobby/Reception	845 sf
2	M Show/RR/Lockers	710 sf
3	W Show/RR/Lockers	740 sf
4	Family RR/Show (2 @ 100)	200 sf
5	MP Room 1	765 sf
6	MP Room 2	950 sf
7	Office/Tennis/Staff	540 sf
8	Party Room	530 sf
9	Staff Ofc (Reception)	100 sf
10	Staff Ofc (Pool)	100 sf
11	Staff Ofc (Medical/1st Aid)	100 sf
12	Juice Bar	150 sf
13	GN RR (2 @ 60)	120 sf
14	Elec/Mech	365 sf
15	Pool Mech (Pump/Filter/Chlor)	1400 sf
16	Pool Deck	25 sf
17	Pool Deck	25 sf
18	Pool Deck	25 sf
19	Pool Deck	25 sf
20	Pool Deck	25 sf
21	Pool Deck	25 sf
22	Pool Deck	25 sf
23	Pool Deck	25 sf
24	Pool Deck	25 sf
25	Pool Deck	25 sf
26	Pool Deck	25 sf
27	Pool Deck	25 sf
28	Pool Deck	25 sf
29	Pool Deck	25 sf
30	Pool Deck	25 sf
31	Pool Deck	25 sf
32	Pool Deck	25 sf
33	Pool Deck	25 sf
34	Pool Deck	25 sf
35	Pool Deck	25 sf
36	Pool Deck	25 sf
37	Pool Deck	25 sf
38	Pool Deck	25 sf
39	Pool Deck	25 sf
40	Pool Deck	25 sf
41	Pool Deck	25 sf
42	Pool Deck	25 sf
43	Pool Deck	25 sf
44	Pool Deck	25 sf
45	Pool Deck	25 sf
46	Pool Deck	25 sf
47	Pool Deck	25 sf
48	Pool Deck	25 sf
49	Pool Deck	25 sf
50	Pool Deck	25 sf
51	Pool Deck	25 sf
52	Pool Deck	25 sf
53	Pool Deck	25 sf
54	Pool Deck	25 sf
55	Pool Deck	25 sf
56	Pool Deck	25 sf
57	Pool Deck	25 sf
58	Pool Deck	25 sf
59	Pool Deck	25 sf
60	Pool Deck	25 sf
61	Pool Deck	25 sf
62	Pool Deck	25 sf
63	Pool Deck	25 sf
64	Pool Deck	25 sf
65	Pool Deck	25 sf
66	Pool Deck	25 sf
67	Pool Deck	25 sf
68	Pool Deck	25 sf
69	Pool Deck	25 sf
70	Pool Deck	25 sf
71	Pool Deck	25 sf
72	Pool Deck	25 sf
73	Pool Deck	25 sf
74	Pool Deck	25 sf
75	Pool Deck	25 sf
76	Pool Deck	25 sf
77	Pool Deck	25 sf
78	Pool Deck	25 sf
79	Pool Deck	25 sf
80	Pool Deck	25 sf
81	Pool Deck	25 sf
82	Pool Deck	25 sf
83	Pool Deck	25 sf
84	Pool Deck	25 sf
85	Pool Deck	25 sf
86	Pool Deck	25 sf
87	Pool Deck	25 sf
88	Pool Deck	25 sf
89	Pool Deck	25 sf
90	Pool Deck	25 sf
91	Pool Deck	25 sf
92	Pool Deck	25 sf
93	Pool Deck	25 sf
94	Pool Deck	25 sf
95	Pool Deck	25 sf
96	Pool Deck	25 sf
97	Pool Deck	25 sf
98	Pool Deck	25 sf
99	Pool Deck	25 sf
100	Pool Deck	25 sf
101	Pool Deck	25 sf
102	Pool Deck	25 sf
103	Pool Deck	25 sf
104	Pool Deck	25 sf
105	Pool Deck	25 sf
106	Pool Deck	25 sf
107	Pool Deck	25 sf
108	Pool Deck	25 sf
109	Pool Deck	25 sf
110	Pool Deck	25 sf
111	Pool Deck	25 sf
112	Pool Deck	25 sf
113	Pool Deck	25 sf
114	Pool Deck	25 sf
115	Pool Deck	25 sf
116	Pool Deck	25 sf
117	Pool Deck	25 sf
118	Pool Deck	25 sf
119	Pool Deck	25 sf
120	Pool Deck	25 sf
121	Pool Deck	25 sf
122	Pool Deck	25 sf
123	Pool Deck	25 sf
124	Pool Deck	25 sf
125	Pool Deck	25 sf
126	Pool Deck	25 sf
127	Pool Deck	25 sf
128	Pool Deck	25 sf
129	Pool Deck	25 sf
130	Pool Deck	25 sf
131	Pool Deck	25 sf
132	Pool Deck	25 sf
133	Pool Deck	25 sf
134	Pool Deck	25 sf
135	Pool Deck	25 sf
136	Pool Deck	25 sf
137	Pool Deck	25 sf
138	Pool Deck	25 sf
139	Pool Deck	25 sf
140	Pool Deck	25 sf
141	Pool Deck	25 sf
142	Pool Deck	25 sf
143	Pool Deck	25 sf
144	Pool Deck	25 sf
145	Pool Deck	25 sf
146	Pool Deck	25 sf
147	Pool Deck	25 sf
148	Pool Deck	25 sf
149	Pool Deck	25 sf
150	Pool Deck	25 sf
151	Pool Deck	25 sf
152	Pool Deck	25 sf
153	Pool Deck	25 sf
154	Pool Deck	25 sf
155	Pool Deck	25 sf
156	Pool Deck	25 sf
157	Pool Deck	25 sf
158	Pool Deck	25 sf
159	Pool Deck	25 sf
160	Pool Deck	25 sf
161	Pool Deck	25 sf
162	Pool Deck	25 sf
163	Pool Deck	25 sf
164	Pool Deck	25 sf
165	Pool Deck	25 sf
166	Pool Deck	25 sf
167	Pool Deck	25 sf
168	Pool Deck	25 sf
169	Pool Deck	25 sf
170	Pool Deck	25 sf
171	Pool Deck	25 sf
172	Pool Deck	25 sf
173	Pool Deck	25 sf
174	Pool Deck	25 sf
175	Pool Deck	25 sf
176	Pool Deck	25 sf
177	Pool Deck	25 sf
178	Pool Deck	25 sf
179	Pool Deck	25 sf
180	Pool Deck	25 sf
181	Pool Deck	25 sf
182	Pool Deck	25 sf
183	Pool Deck	25 sf
184	Pool Deck	25 sf
185	Pool Deck	25 sf
186	Pool Deck	25 sf
187	Pool Deck	25 sf
188	Pool Deck	25 sf
189	Pool Deck	25 sf
190	Pool Deck	25 sf
191	Pool Deck	25 sf
192	Pool Deck	25 sf
193	Pool Deck	25 sf
194	Pool Deck	25 sf
195	Pool Deck	25 sf
196	Pool Deck	25 sf
197	Pool Deck	25 sf
198	Pool Deck	25 sf
199	Pool Deck	25 sf
200	Pool Deck	25 sf
201	Pool Deck	25 sf
202	Pool Deck	25 sf
203	Pool Deck	25 sf
204	Pool Deck	25 sf
205	Pool Deck	25 sf
206	Pool Deck	25 sf
207	Pool Deck	25 sf
208	Pool Deck	25 sf
209	Pool Deck	25 sf
210	Pool Deck	25 sf
211	Pool Deck	25 sf
212	Pool Deck	25 sf
213	Pool Deck	25 sf
214	Pool Deck	25 sf
215	Pool Deck	25 sf
216	Pool Deck	25 sf
217	Pool Deck	25 sf
218	Pool Deck	25 sf
219	Pool Deck	25 sf
220	Pool Deck	25 sf
221	Pool Deck	25 sf
222	Pool Deck	25 sf
223	Pool Deck	25 sf
224	Pool Deck	25 sf
225	Pool Deck	25 sf
226	Pool Deck	25 sf
227	Pool Deck	25 sf
228	Pool Deck	25 sf
229	Pool Deck	25 sf
230	Pool Deck	25 sf
231	Pool Deck	25 sf
232	Pool Deck	25 sf
233	Pool Deck	25 sf
234	Pool Deck	25 sf
235	Pool Deck	25 sf
236	Pool Deck	25 sf
237	Pool Deck	25 sf
238	Pool Deck	25 sf
239	Pool Deck	25 sf
240	Pool Deck	25 sf
241	Pool Deck	25 sf
242	Pool Deck	25 sf
243	Pool Deck	25 sf
244	Pool Deck	25 sf
245	Pool Deck	25 sf
246	Pool Deck	25 sf
247	Pool Deck	25 sf
248	Pool Deck	25 sf
249	Pool Deck	25 sf
250	Pool Deck	25 sf
251	Pool Deck	25 sf
252	Pool Deck	25 sf
253	Pool Deck	25 sf
254	Pool Deck	25 sf
255	Pool Deck	25 sf
256	Pool Deck	25 sf
257	Pool Deck	25 sf
258	Pool Deck	25 sf
259	Pool Deck	25 sf
260	Pool Deck	25 sf
261	Pool Deck	25 sf
262	Pool Deck	25 sf
263	Pool Deck	25 sf
264	Pool Deck	25 sf
265	Pool Deck	25 sf
266	Pool Deck	25 sf
267	Pool Deck	25 sf
268	Pool Deck	25 sf
269	Pool Deck	25 sf
270	Pool Deck	25 sf
271	Pool Deck	25 sf
272	Pool Deck	25 sf
273	Pool Deck	25 sf
274	Pool Deck	25 sf
275	Pool Deck	25 sf
276	Pool Deck	25 sf
277	Pool Deck	25 sf
278	Pool Deck	25 sf
279	Pool Deck	25 sf
280	Pool Deck	25 sf
281	Pool Deck	25 sf
282	Pool Deck	25 sf
283	Pool Deck	25 sf
284	Pool Deck	25 sf
285	Pool Deck	25 sf
286	Pool Deck	25 sf
287	Pool Deck	25 sf
288	Pool Deck	25 sf
289	Pool Deck	25 sf
290	Pool Deck	25 sf
291	Pool Deck	25 sf
292	Pool Deck	25 sf
293	Pool Deck	25 sf
294	Pool Deck	25 sf
295	Pool Deck	25 sf
296	Pool Deck	25 sf
297	Pool Deck	25 sf
298	Pool Deck	25 sf
299	Pool Deck	25 sf
300	Pool Deck	25 sf
301	Pool Deck	25 sf
302	Pool Deck	25 sf
303	Pool Deck	25 sf
304	Pool Deck	25 sf
305	Pool Deck	25 sf
306	Pool Deck	25 sf
307	Pool Deck	25 sf
308	Pool Deck	25 sf
309	Pool Deck	25 sf
310	Pool Deck	25 sf
311	Pool Deck	25 sf
312	Pool Deck	25 sf
313	Pool Deck	25 sf
314	Pool Deck	25 sf
315	Pool Deck	25 sf
316	Pool Deck	25 sf
317	Pool Deck	25 sf
318	Pool Deck	25 sf
319	Pool Deck	25 sf
320	Pool Deck	25 sf
321	Pool Deck	25 sf
322	Pool Deck	25 sf
323	Pool Deck	25 sf
324	Pool Deck	25 sf
325	Pool Deck	25 sf
326	Pool Deck	25 sf
327	Pool Deck	25 sf
328	Pool Deck	25 sf
329	Pool Deck	25 sf
330	Pool Deck	25 sf
331	Pool Deck	25 sf
332	Pool Deck	25 sf
333	Pool Deck	25 sf
334	Pool Deck	25 sf
335	Pool Deck	25 sf
336	Pool Deck	25 sf
337	Pool Deck	25 sf
338	Pool Deck	25 sf
339	Pool Deck	25 sf
340	Pool Deck	25 sf
341	Pool Deck	25 sf
342	Pool Deck	25 sf
343	Pool Deck	25 sf
344	Pool Deck	25 sf
345	Pool Deck	25 sf
346	Pool Deck	25 sf
347	Pool Deck	25 sf
348	Pool Deck	25 sf
349	Pool Deck	25 sf
350	Pool Deck	25 sf
351	Pool Deck	25 sf
352	Pool Deck	25 sf
353	Pool Deck	25 sf
354	Pool Deck	25 sf
355	Pool Deck	25 sf
356	Pool Deck	25 sf
357	Pool Deck	25 sf
358	Pool Deck	25 sf
359	Pool Deck	25 sf
360	Pool Deck	25 sf
36		

Team Presentations



Views



Site Plan / First Floor (Pool Deck Level)



Programming Info

Plan Key

1	Lobby/Reception	845 sf
2	M Show/RR/Lockers	710 sf
3	W Show/RR/Lockers	740 sf
4	Family RR/Show (2 @ 100)	200 sf
5	MP Room 1	765 sf
6	MP Room 2	950 sf
7	Office/Tennis/Staff	540 sf
8	Party Room	530 sf
9	Staff Ofc (Reception)	100 sf
10	Staff Ofc (Pool)	100 sf
11	Staff Ofc (Medical/1st Aid)	100 sf
12	Juice Bar	150 sf
13	GN RR (2 @ 60)	120 sf
14	Elec/Mech	365 sf
15	Pool Mech (Pump, Filters, Acid, Chem)	1400 sf
16	Janitor	25 sf
17	Storage	145 sf
Room Area Total - Net SF		7785 sf
Building Area - Gross SF		9330 sf
2nd Floor Terraces/Walkways		2800 sf

Team Number _____

Team Captain _____

Notes

Team Presentations



HILLSIDE PARK

Piedmont Community Pool

- PAC Meeting #2 – Pre-Community Workshop Meeting #1
Presentation of Workshop Series October 19, 2021 COMPLETED
- Community Workshop 1A an 1B
Gallery Walk November 2, 2021 COMPLETED
- Community Workshop #2
2 to 3 Initial Programming Alternatives and Concepts November 16, 2021 COMPLETED
- PAC Meeting #3 – Post-Community Workshop Meeting #2
• Planning Commission Update November 18, 2021 COMPLETED
December 13 COMPLETED
- Community Workshop #3
Preferred Programming and Concept Direction December 14, 2021 TONIGHT!

- PAC Meeting #4 – Post-Community Workshop Meeting #3 December 16, 2021
- PAC Meeting #5 – Pre-City Council Session – Week of January 3, 2022
- PAC Meeting #6 (If needed) Pre-City Council Session Week of January 10, 2022
- Planning Commission Update – Possible Special Session January
- Planning Commission Update – Possible Special Session mid-March
- Planning Commission Update – Possible Special Session mid-April
- City Council Presentation – Advance Design January/February
- Design Documents Complete/Bid Q4 of 2022
- Construction Start Q1 of 2023
- *SPLASH* Summer of 2024





Thank You Summer 2024 Splash

